



Column #27, May 1997 by Scott Edwards:

Measure Water Level Without Getting Wet

Make a sensitive water sensor from hardware-store parts

MY FAVORITE Stamp projects are like magic tricks. Take a little science knowledge and some hardware-store items, add our favorite BASIC computer, and—presto!—a neat application.

This month's application combines magic with down-to-earth practicality to create a water-level sensor. The method can be scaled to work with any container from a bucket to a irrigation tank to a swimming pool.

Measuring water level

Water has quite a few properties that can be used to measure its quantity. Here's an (incomplete) list of possible measurement methods:

- Measure the position of a float on the surface of the water.
- Weigh the water and calculate the volume.

Column #27: Measure Water Level Without Getting Wet

- Bounce a sonar or radar ping off the surface of the water and measure its echo timing to determine the height of water.
- Thump the water tank and measure the frequency at which it rings. The higher the water level, the lower the pitch.
- Air is a better thermal insulator than water; use a self-heating sensor to locate the point at which air and water meet by the change in thermal response.
- Water cannot be compressed as air can. Use a sealed tank, a pressure sensor, and air supply to determine the proportion of air to water in the tank.
- Water is clear like air but has a different refractive index (Light-bending characteristic: Look at a straw standing in a glass of water and it appears to be broken at the air-water junction). Use an optical sensor to detect the point at which the air meets the water.
- Water (with common impurities) is a better electrical conductor than air. Use electrodes to measure this property.
- Measure the amount of water pumped into the tank and the amount pumped out, and balance the books to determine the amount remaining in the tank.
- The dielectric constant (an important factor in determining the capacitance of two conductors separated by an insulator) of water is very different from that of air. Measure the capacitance across the tank to determine the proportion of water to air and therefore the level of the water.

I'm sure that with a little time and imagination you could double the length of that list.

The thing I find interesting about the list is that the methods that are the easiest to understand can also be the hardest or most expensive to implement. Take the first two: a float sounds great. You can picture it immediately; rig a lever arm on a potentiometer shaft and fix a float to the end of the lever. Use the Stamp's built-in Pot instruction to measure the pot setting, and convert that result to the appropriate volume of water.

Unless the tank is 10 feet high and 4 feet in diameter: Using trigonometry, you can calculate that the lever connected to the pot would also have to be about 10 feet long, if we assume that the float would work over an angle of say 75 degrees. (If it went a full 90 degrees, it could get stuck in the down position.)

So floats and lever arms might be better for broad, shallow tanks. But even then there's the problem of protecting the pot from the effects of a humid environment.

Figure 27.1: Water level test setup

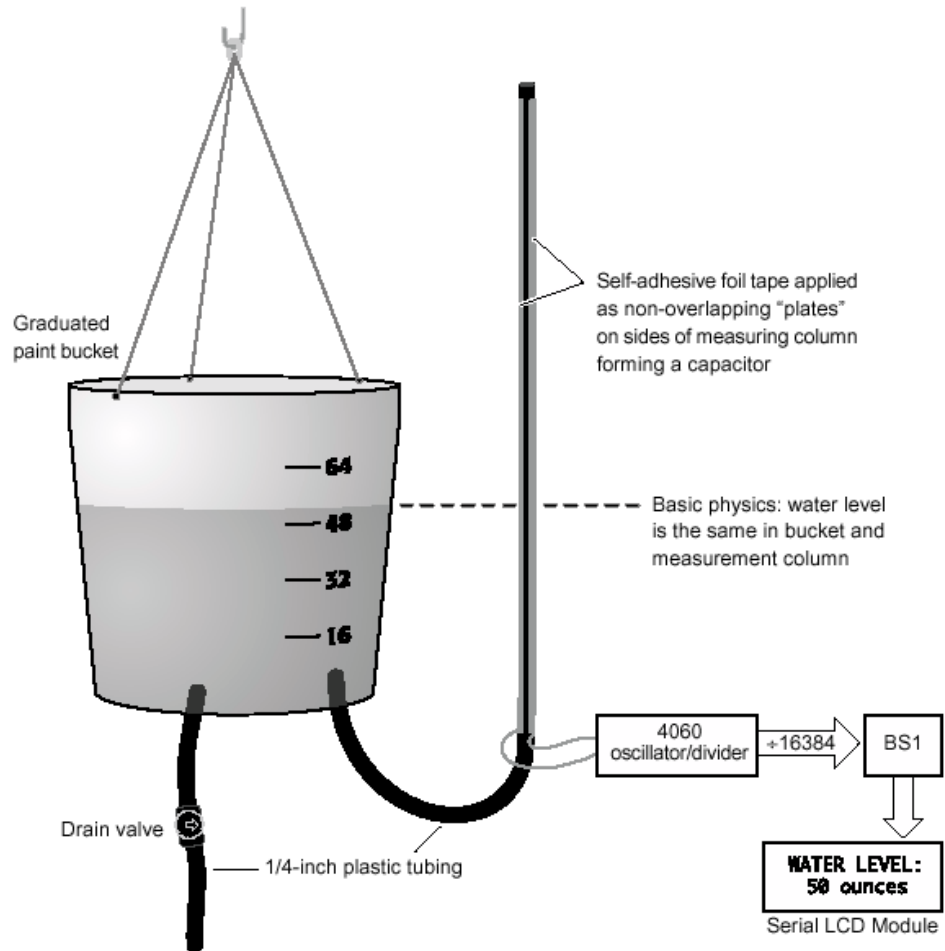

OK, what about weight? Your choices here range from elegant but expensive (an electronic load cell and analog signal-conditioning circuitry, both designed specifically for the max weight and weight range of the tank), to cheap but cumbersome (a spring-plunger arrangement coupled to a linear-travel pot?).

The last item on the list—dielectric constant— sounds difficult, but turns out to be a piece of cake to implement. Figure 27.1 shows the general arrangement I used to test the idea, while Figure 27.2 is a schematic of the electronics.

Figure 27.2: Schematic of H2O level test setup

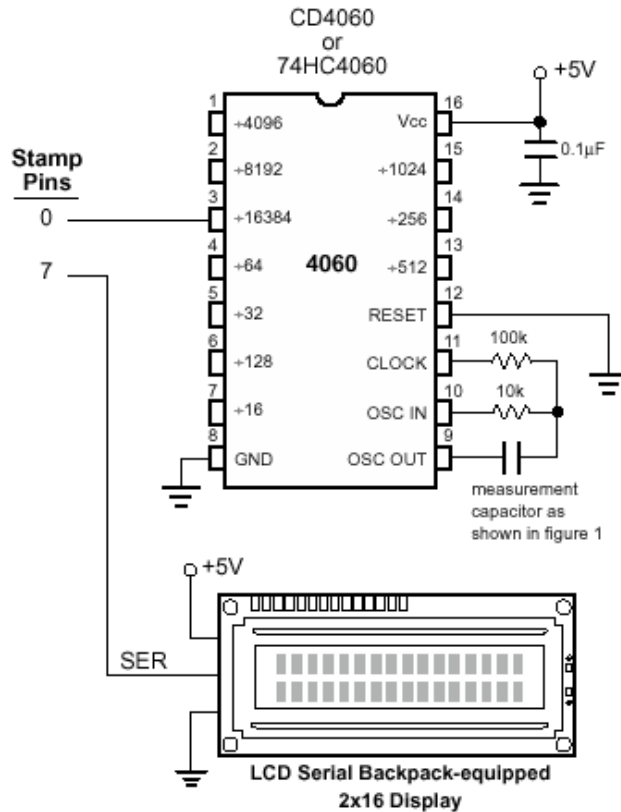

I used aluminum foil tape to form the measuring-column capacitor. This tape is a common hardware-store item used to repair rain gutters and join sections of foil-faced insulation.

My first job was to apply it to the measuring column (a section of 1/4" drip-irrigation tubing) in two non-overlapping stripes. I found an easy way to do this. I got a piece of IC carrier tubing for skinny (0.3") ICs. There's a 1/4" trench that runs along the length of this tube. I stuffed the measuring tube into the trench, and taped it in place with the foil tape. Using a razor knife, I trimmed the foil tape that held the measuring tube to the IC tube, and was left with a perfect stripe of foil tape. I rotated the measuring tube and repeated the process to get the second stripe.

Column #27: Measure Water Level Without Getting Wet

The second task with the foil tape was hooking it up to my circuit. Aluminum tape is not the best stuff for this application, because it's difficult to make a reliable electrical connection to it. However, it had the huge advantage of being on hand the day that I had the urge to test this idea! And the hardware store also carries a conductive grease (trade name Ox-Gard) that prevents the oxidation that spoils aluminum-to-copper connections.

I smeared some Ox-Gard on the ends of the foil, stuffed them into crimp-type butt connectors, put short wires to my 4060 circuit in the other ends of the connectors, and crimped hard.

If you plan to replicate this setup, consider using self-adhesive copper-foil tape. Digi-Key (1-800-344-4539) carries it under part numbers 3M1181A-ND, 3M1181B-ND and 3M1181C-ND (1/4", 1/2" and 1" widths by 18-yard lengths, respectively). The adhesive is conductive, so you can connect to a circuit by simply sticking it down.

Once I had my test setup assembled, I connected a Counterfeit (my company's BS1 kit) to the 4060 to get a feel for the raw data. I took Pulsin measurements and got the following readings:

Water Level	Pulsin Result
16 oz	3683
32 oz	3743
48 oz	3798
64 oz	3848

I repeated the measurements several times, and to my amazement, they were rock-steady, and within 1 to 2 units of identical for each of the liquid levels. Things are not usually this easy in the world of homemade sensors. I dumped the numbers into a graph, and found that the relationship between water level and pulse width was darn near linear (Figure 27.3).

The slight deviation from a straight line predicts a 1-ounce error in the middle of the range. And the final program (Listing 27.1) exhibits that minor quirk. But gosh, this is a talking dog—you don't correct his grammar!

Column #27: Measure Water Level Without Getting Wet

Figure 27.3: Graph of Pulsin versus water level.

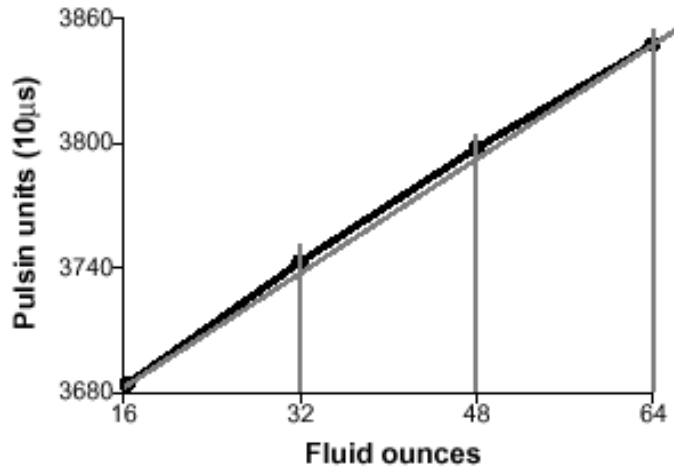

Summary

There are quite a few opportunities to experiment with this application. The calibration is likely to vary with temperature, since the measuring tube is likely to shrink and swell slightly, changing the plate spacing, and therefore the capacitance. In a practical application of this idea, you would also have to prevent people and objects from getting too close to the measuring column, as their proximity would also influence capacitance. This might mean simply enclosing the measuring column in another tube a couple of inches in diameter.

While I was working on this column, I was struck by how many Stamp applications follow this general pattern of reading a sensor, scaling the data to units, and presenting the units on a display. At about the same time, a customer called to ask whether I'd considered offering an all-in-one computer/display package based on the BS1. I take suggestions seriously, as you can see from Figure 27.4.

The new BS1/LCD kits are available with LED-backlit or non-backlit 2x16 LCDs.⁹ As the photo shows, there's a fair amount of prototyping area left over for custom circuitry. The 4060 used in this month's water-level application would fit with plenty of room to spare. And since the display takes only one of the BS1's eight I/O lines, there's room for

⁹ The BS1/LCD kit has been discontinued by Scott Edwards Electronics.

expansion.

Figure 27.4: New kit combines BS1 and LCD in one package

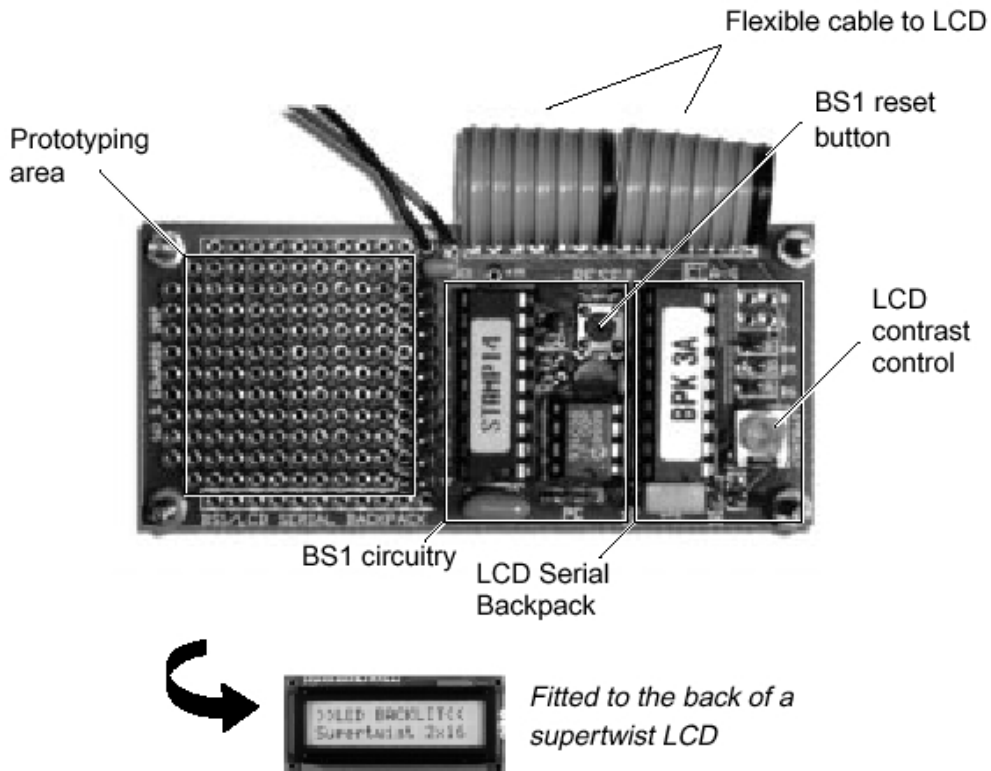

Column #27: Measure Water Level Without Getting Wet

```
' Program Listing 27.1. Water-level measurement
' Program: H2OLEVEL.BAS (Measure water level via variable capacitance)
' This program works with the circuit shown in the accompanying
' article to measure the water level in a plastic-tube measuring
' column. Since water 'seeks its own level,' such a measuring
' column can be used to measure water levels in containers from
' a bucket to a a lake! The program is straightforward--most
' of the magic is in the circuit. An oscillator whose frequency
' depends in part on the capacitance of the measuring column
' is divided by 16,384 by a ripple counter. This program times
' the low-high-low (pulse) portion of the output and converts it
' to fluid ounces. The conversion is based on a series of manual
' measurements, and depends (obviously) on the characteristics of
' the measuring column and the size of the container being monitored.

'====Variables and Constants
SYMBOL level = w4      ' Water level measurement in Pulsin units.
SYMBOL oz = b6        ' Measurement converted to fluid ounces.
SYMBOL checks = b5    ' Number of out-of-range readings in a row.
SYMBOL lcd = 7        ' Serial LCD on pin 7.
SYMBOL I = 254        ' Instruction prefix for LCD.
SYMBOL clsLCD = 1     ' Clear-screen instruction for LCD.
SYMBOL line2 = 196    ' Location on 2nd line.

'====Main Program
' This code measures the incoming pulses and scales them to
' ounces based on previous manual measurements. It also keeps
' track of out-of-range readings and, if it gets 10 in a row,
' displays a message on the LCD. By waiting for more than
' one bad reading, the program is tolerant of glitches and noise
' that might otherwise cause occasional false readings.
setup:
  serout lcd,n2400,(I,clsLCD, " WATER LEVEL:" ) ' Label LCD screen.
restart:
  checks = 0          ' Reset out-of-range counter.
again:
  if checks > 10 then handleError ' > 10 bad readings? Tell user.
  checks = checks + 1 ' Increment checks.
  pulsln 0,1,level    ' Take a raw reading.
  if level < 3683 then again ' Out of range (low)? Try again.
  if level > 3850 then again ' Out of range (high)? Try again.
  oz = level - 3683 * 16 / 55 + 16 ' In range: Calc ounces.
  serout lcd,n2400,(I,line2,#oz," ounces") ' Display on LCD.
goto restart        ' Do it again.

'====Error Handler
' If 10 pulsln readings in a row are out of range, the bucket may be
' empty or overflowing, or the electronics are malfunctioning (wet?).
' These routines print appropriate messages on the LCD.
handleError:
  if level < 3683 then empty
  serout lcd,n2400,(I,line2, "OVERFLOW ")
  pause 1000
```

Column #27: Measure Water Level Without Getting Wet

```
goto restart
empty:
  serout lcd,n2400,(I,line2, "-EMPTY- ")
  pause 1000
goto restart
```