



Image Formation II

Chapter 1 (Forsyth&Ponce)

Guido Gerig

CS-GY 6643, Spring 2016

Acknowledgements:

- Slides used/modified from Prof. Trevor Darrell
(trevor@eecs.berkeley.edu)
(<http://www.eecs.berkeley.edu/~trevor/CS280.html>)



Recall, perspective effects...

- Far away objects appear smaller

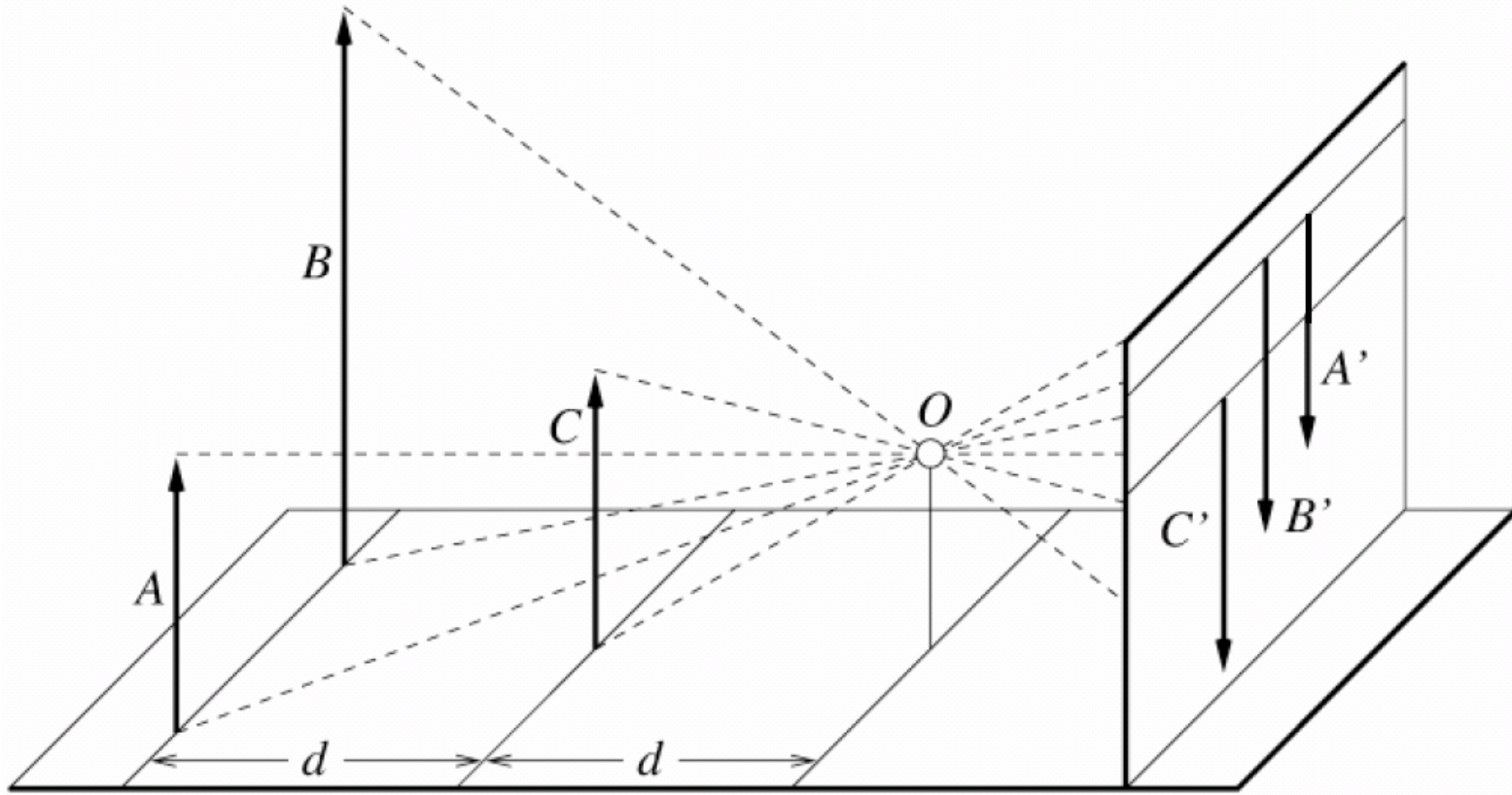

Perspective effects



Perspective effects





Perspective effects

- Parallel lines in the scene intersect in the image
- Converge in image on horizon line

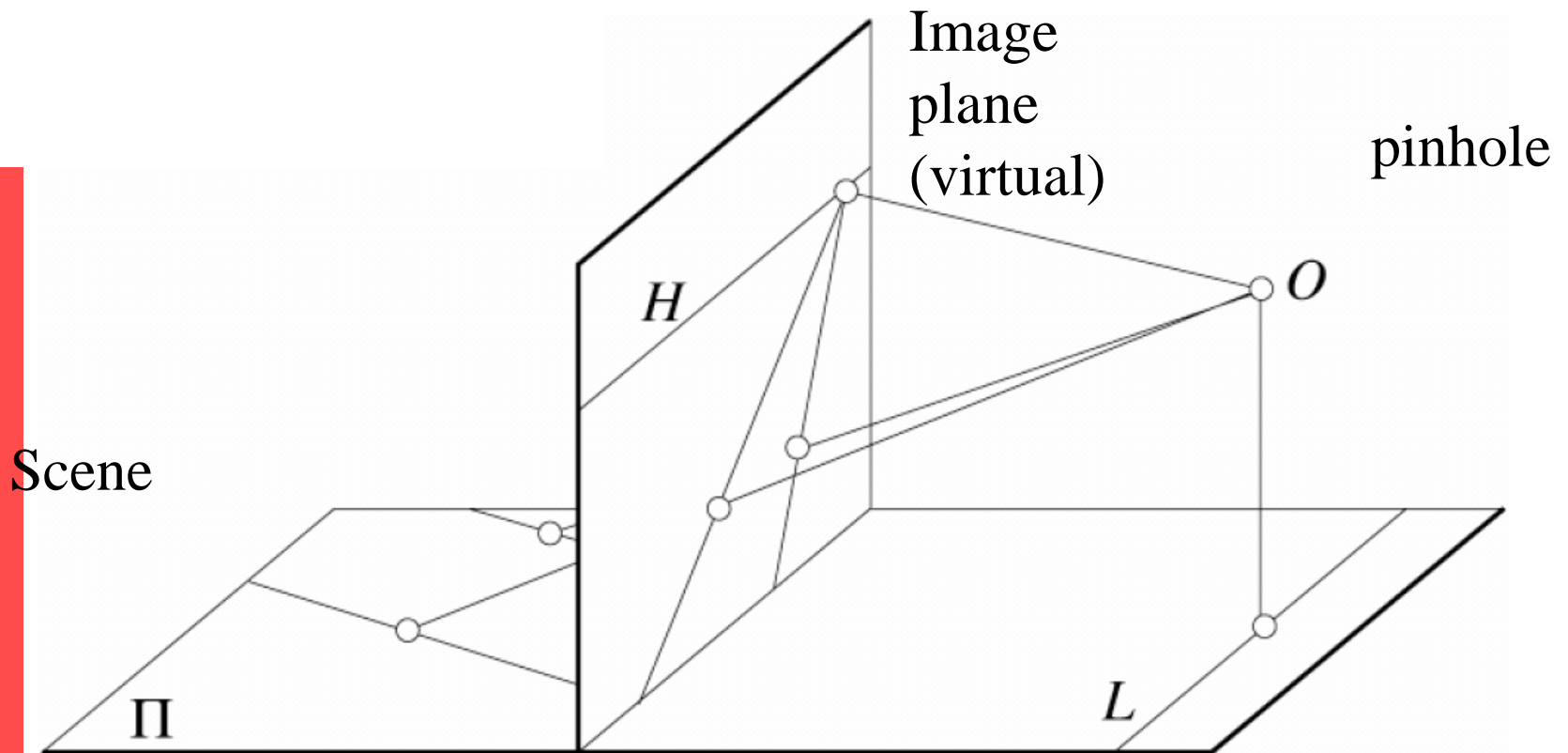



Projection properties

- Many-to-one: any points along same ray map to same point in image
- Points \rightarrow ?
 - **points**
- Lines \rightarrow ?
 - **lines** (collinearity preserved)
- Distances and angles are / are not ?
preserved
 - **are not**
- Degenerate cases:
 - Line through focal point projects to a point.
 - Plane through focal point projects to line
 - Plane perpendicular to image plane projects to part of the image.

Weak perspective



- Approximation: treat magnification as constant
- Assumes scene depth \ll average distance to camera

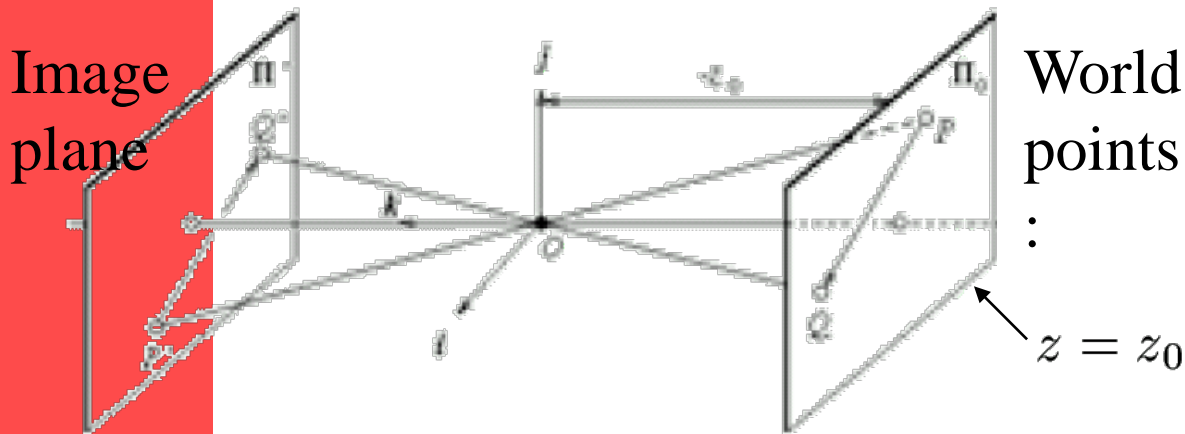

$$x' = f \frac{x}{z} \approx \frac{f}{z_0} x$$
$$y' = f \frac{y}{z} \approx \frac{f}{z_0} y$$

Orthographic projection

- Given camera at **constant** distance from scene
- World points projected along rays parallel to optical axis

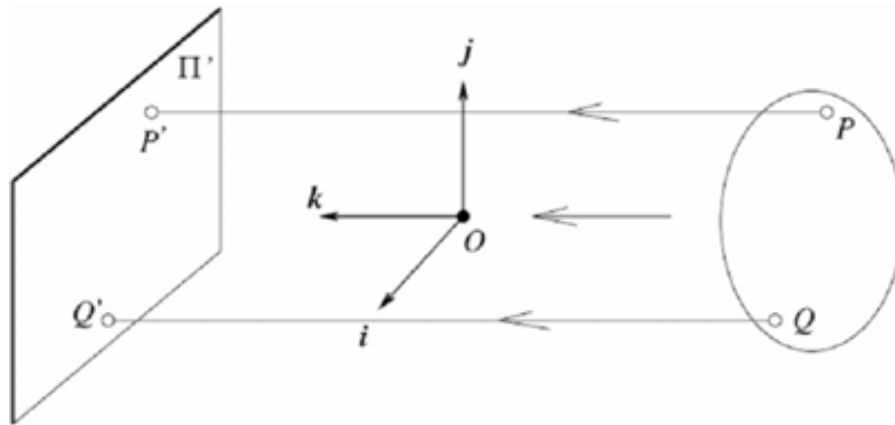

$$\begin{aligned}x' &= x \\y' &= y\end{aligned}$$

$$\begin{bmatrix} 1 & 0 & 0 & 0 \\ 0 & 1 & 0 & 0 \\ 0 & 0 & 0 & 1 \end{bmatrix} \begin{bmatrix} x \\ y \\ z \\ 1 \end{bmatrix} = \begin{bmatrix} x \\ y \\ 1 \end{bmatrix} \Rightarrow (x, y)$$

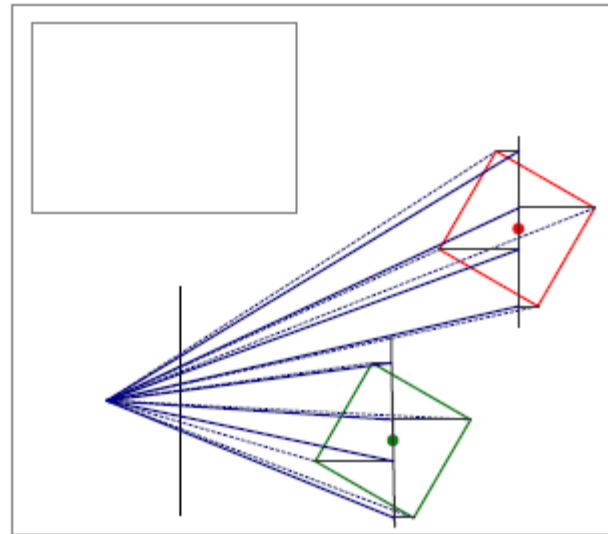
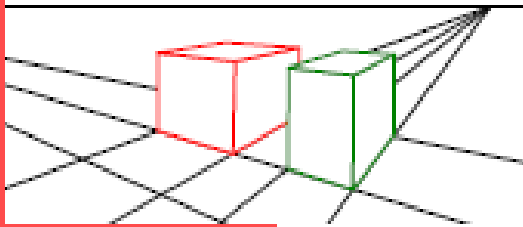

(c) scaled orthography

$$\mathbf{x} = [s\mathbf{I}_{2 \times 2} | \mathbf{0}] \mathbf{p}.$$

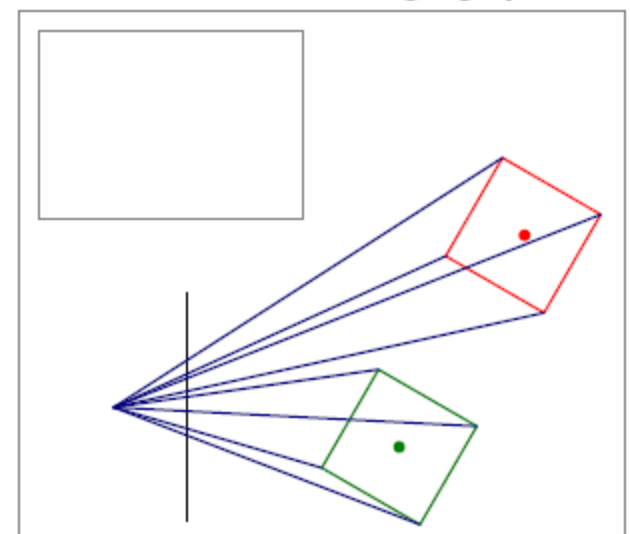

(e) perspective

$$\mathbf{x} = \mathcal{P}_z(\mathbf{p}) = \begin{bmatrix} x/z \\ y/z \\ 1 \end{bmatrix}.$$

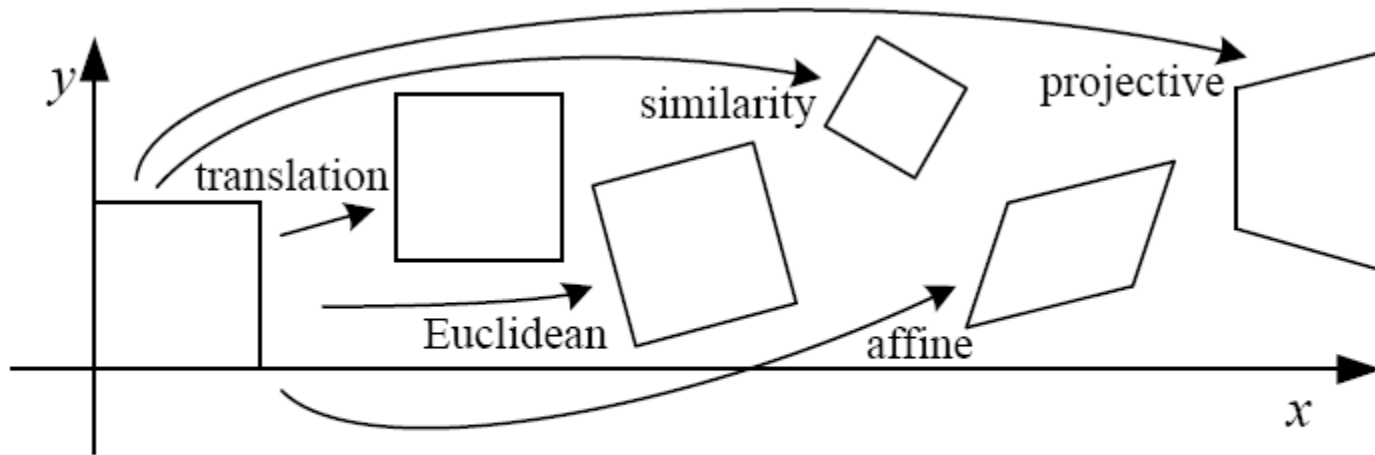







Figure 2.4: *Basic set of 2D planar transformations*







2D

Name	Matrix	# D.O.F.	Preserves:	Icon
translation	$\begin{bmatrix} I & & t \end{bmatrix}_{2 \times 3}$	2	orientation + ...	
rigid (Euclidean)	$\begin{bmatrix} R & & t \end{bmatrix}_{2 \times 3}$	3	lengths + ...	
similarity	$\begin{bmatrix} sR & & t \end{bmatrix}_{2 \times 3}$	4	angles + ...	
affine	$\begin{bmatrix} A \end{bmatrix}_{2 \times 3}$	6	parallelism + ...	
projective	$\begin{bmatrix} \tilde{H} \end{bmatrix}_{3 \times 3}$	8	straight lines	



3D

Name	Matrix	# D.O.F.	Preserves:	Icon
translation	$\left[\begin{array}{c c} \mathbf{I} & \mathbf{t} \end{array} \right]_{3 \times 4}$	3	orientation + ...	
rigid (Euclidean)	$\left[\begin{array}{c c} \mathbf{R} & \mathbf{t} \end{array} \right]_{3 \times 4}$	6	lengths + ...	
similarity	$\left[\begin{array}{c c} s\mathbf{R} & \mathbf{t} \end{array} \right]_{3 \times 4}$	7	angles + ...	
affine	$\left[\begin{array}{c} \mathbf{A} \end{array} \right]_{3 \times 4}$	12	parallelism + ...	
projective	$\left[\begin{array}{c} \tilde{\mathbf{H}} \end{array} \right]_{4 \times 4}$	15	straight lines	



Other types of projection

- Lots of intriguing variants...
- (I'll just mention a few fun ones)



360 degree field of view...



- Basic approach
 - Take a photo of a parabolic mirror with an orthographic lens (Nayar)
 - Or buy one a lens from a variety of omnicam manufacturers...
 - See <http://www.cis.upenn.edu/~kostas/omni.html>

Tilt-shift



http://www.northlight-images.co.uk/article_pages/tilt_and_shift_ts-e.html

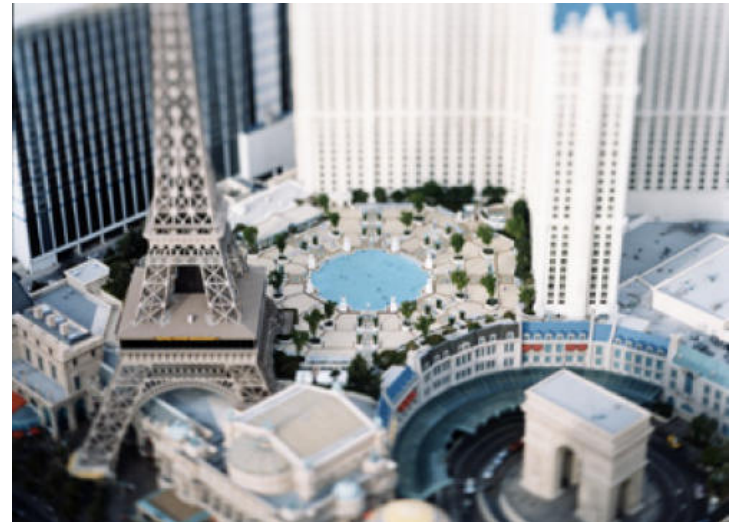

Tilt-shift images from [Olivo Barbieri](#)
and Photoshop [imitations](#)



tilt, shift

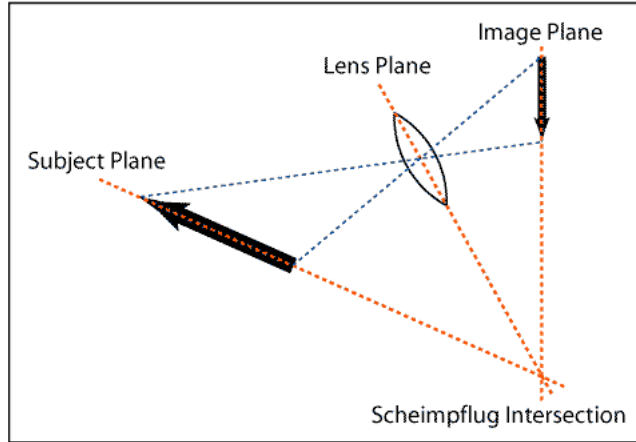

wikipedia

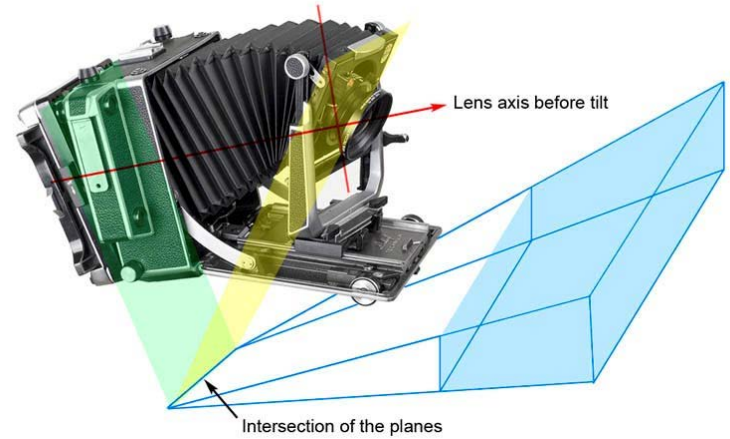

<http://www.luminous-landscape.com/tutorials/focusing-ts.shtml>



http://en.wikipedia.org/wiki/Tilt-shift_photography

Tilt-shift perspective correction



Three photos of the 1858 Robert M. Bashford House Madison, Dane County, Wisconsin, placed on the National Register of Historic Places in 1973.

In the first photo, the camera has been leveled, but no shift lens was used. The top of the house isn't in the picture at all.

The second shows what results when the same camera without a shift lens is tilted to get the whole house. The house looks like it is falling over backwards.

The third view, from the same angle, but this time with a shift, or PC, lens gives the results wanted.

normal lens



tilt-shift lens

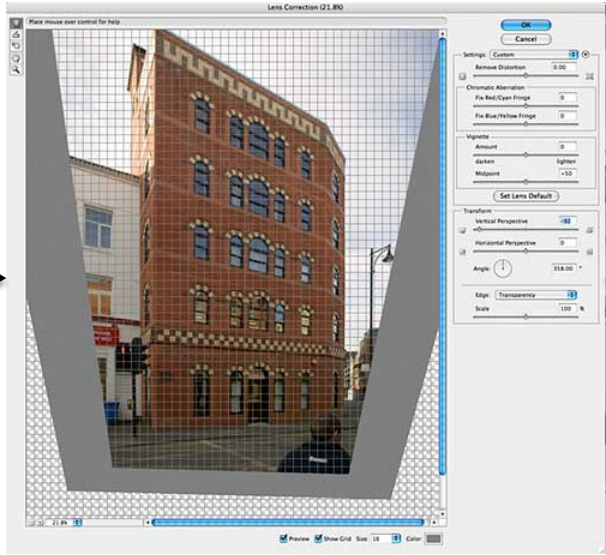

Rotating sensor (or object)

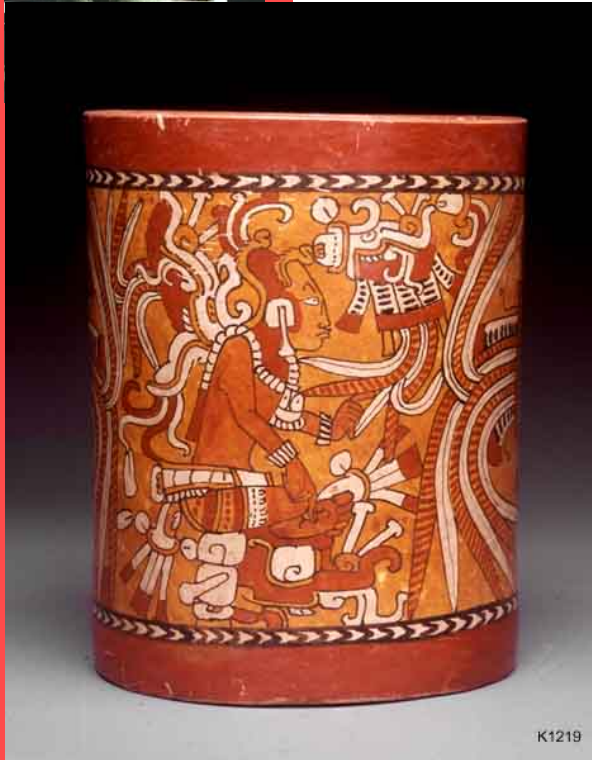

Rollout Photographs © Justin Kerr
<http://research.famsi.org/kerrmaya.html>

Also known as “cyclographs”, “peripheral images”